

550B1024

Wi-Fi

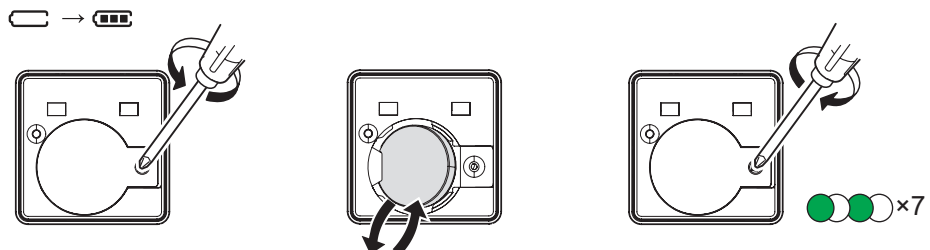
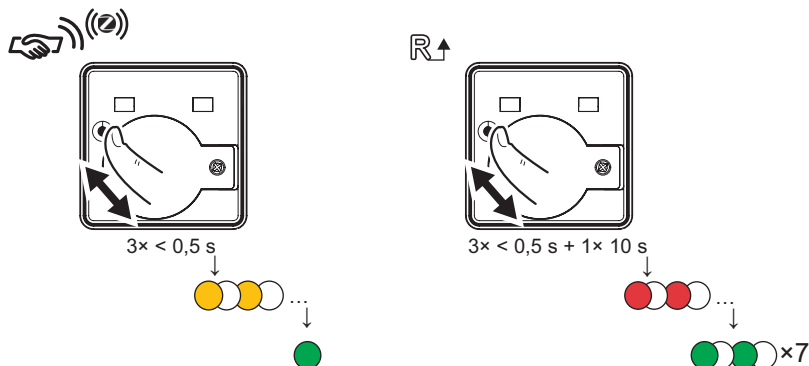
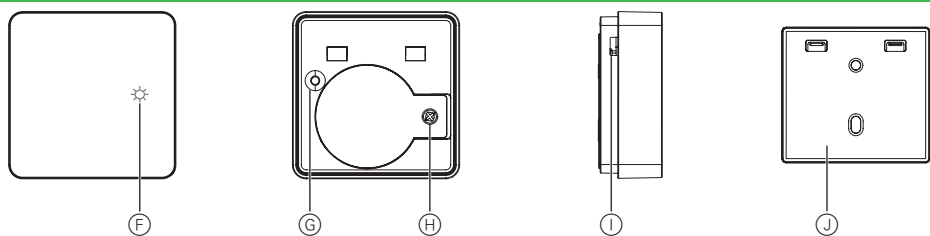
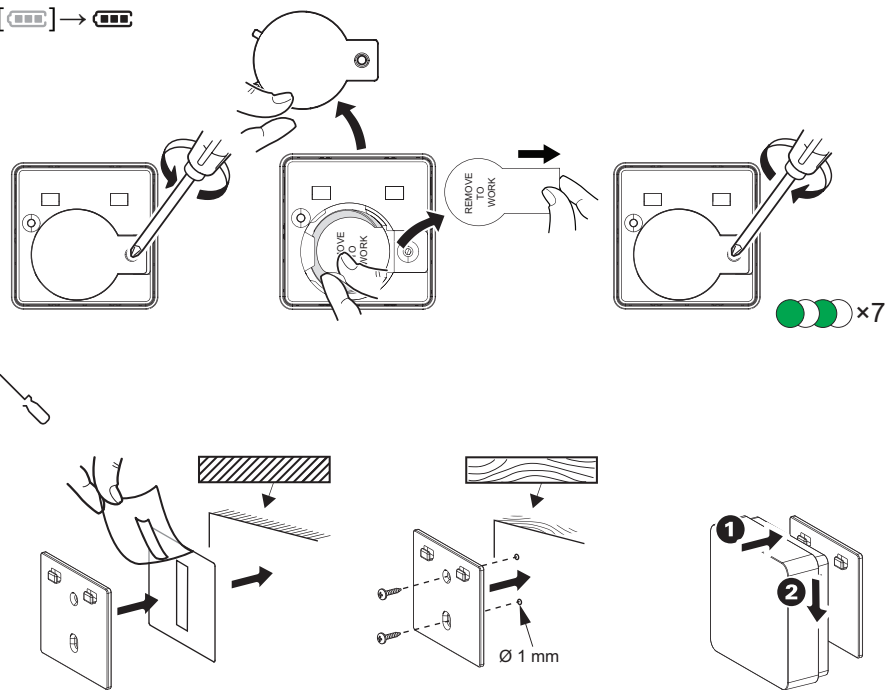
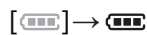
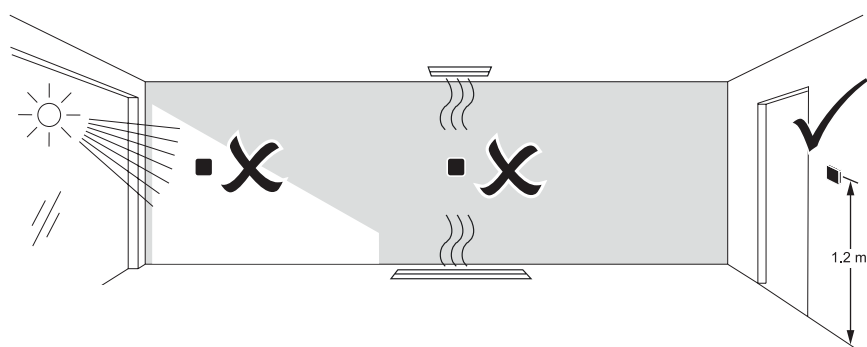
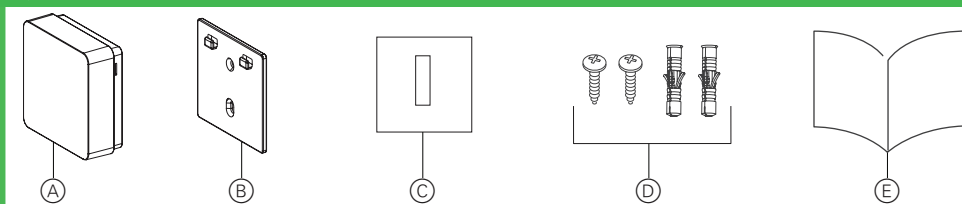

Forudsætninger

Download Wisir app'en til din smartphone / tablet, og installer Wisir Gateway for at konfigurere og styre dine Wisir enheder.

Yderligere information

Detaljeret produktinformation er tilgængelig online i **systemvejledningen**: Scan QR-koden eller følg linket.

<https://www1.lk.dk/wisir>

For din sikkerhed

ADVARSEL

RISIKO FOR SKADE PÅ ENHEDEN

Brug altid produktet i overensstemmelse med de specificerede tekniske data.
Manglende overholdelse af disse instruktioner kan resultere i skader på udstyr.

Lær produktet at kende

Wisir trådløs fugt- og temperatursensor (i det følgende benævnt **sensor**) kombinerer to sensorer i en enhed. Sensoren måler temperatur og fugtighed på den lokation, hvor sensoren er installeret. Når sensoren er tilsluttet Wisir Gateway, rapporterer den direkte temperatur- og fugtighedsdata til Gateway'en. Når batteriet er lavt (mindre end 10%), blinker status-LED orange en gang pr. minut, og en meddelelse sendes til Gateway'en.

Indhold i pakken

- (A) Sensor
- (B) Bundplade
- (C) Selvklebende klæbepude
- (D) Skruer: 2 × ST4,2 × 25 mm med vægplugs
- (E) Installations instruktioner

Valg af installationslokation

Installer sensoren det foreslåede sted.

- i** Installer ikke sensoren et sted, hvor der er stærkt sollys eller vind (for eksempel tæt på ventilation).

Montering af sensoren

Fjernelse af batteriets isolationsfilm



Montering

- i** Til træ- eller plastoverflader skal du bruge enten klæbepuderne eller monteringsskrue.
- Hvis du bruger skrue, skal du forbore et hul på 1 mm.
- Brug kun klæbepuder til metaloverflader.

Bejenings elementer

- (F) Status lysdioder
- (G) Funktionsknap
- (H) Bunddækselsskrue
- (I) Temperatur og fugtigheds sensor hul

i For at sikre nøjagtig måling af temperatur og fugtighed må du ikke blokere sensorhullerne.

- (J) Monteringsplade

Indstilling af sensoren

i Fjern enheden fra monteringspladen for at få adgang til funktionsknappen (G).

Opret forbindelse til Wisir Gateway

- 1 Kort tryk på (<0,5 s) funktionsknappen 3 gange. Sensoren søger efter et tilgængeligt Zigbee-netværk. Status-lysdioden lyser grønt, hvis sensoren tilsluttes Gateway'en.
- 2 Følg instruktionerne i Wisir app'en for at indstille sensorparametre gennem Gateway'en.

Reset sensoren

Tryk kortvarigt (<0,5 s) på funktionsknappen 3 gange, og tryk derefter lang tid på funktionsknappen >10 sekunder for at nulstille sensoren til fabriksstand.

i Alle konfigurationsdata, brugerdata og netværksdata slettes.

Udskiftning af batteriet

Betydning af status lysdiode

Se systemvejledning.

Fejlfinding

Se systemvejledning.

Tekniske data

Batteri	3 V d.c., CR2450
Batteri levetid	Op til 5 år (kan variere afhængig af brug, hyppighed af firmwareopdatering og miljø)
Mærkeeffekt	≤90 mW
Frekvensområde	2,4 GHz
Maksimal transmissionseffekt	≤7 dBm
Kapslingsklasse	IP20
Driftstemperatur	-10 °C til 50 °C
Temperatur-nøjagtighed	±1,5 °C
Temperatur-opløsning	0,1 °C
Relativ fugtighed	10 % til 95 %
Fugtigheds-nøjagtighed	±5 %
Dimensioner (H × B × D)	45,0 × 45,0 × 17,2 mm
EU deklaration	1003619-0
Certifikater	Zigbee 3.0



Bortskaf enheden separat fra husholdningsaffald på et godkendt opsamlingssted. Professionel genanvendelse beskytter mennesker og miljø mod potentielle negative effekter.

Varemærker

- Zigbee® er et registreret varemærke tilhørende Zigbee Alliance.
- Apple® og App Store® er mærkenavne eller registrerede varemærker tilhørende Apple Inc.
- Google Play™ Store og Android™ er mærkenavne eller registrerede varemærker tilhørende Google Inc.

Andre mærker og registrerede varemærker tilhører deres relevante ejere.

EU-overensstemmelseserklæring

Schneider Electric Danmark A/S erklærer hermed, at dette produkt er i overensstemmelse med de væsentlige krav og andre relevante bestemmelser i RADIO EQUIPMENT DIRECTIVE 2014/53 / EU. Overensstemmelseserklæringen kan downloades på adressen se.com/docs.

Lauritz Knudsen

Schneider Electric Danmark A/S, Lautrupvang 1, 2750 Ballerup, Telefon: +45 88 30 20 00, www.lk.dk

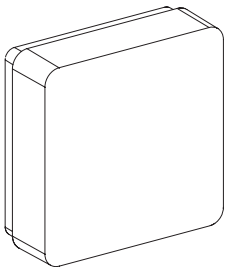

550B1024

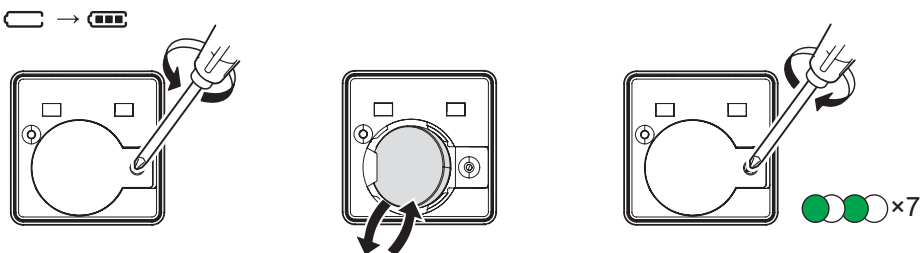
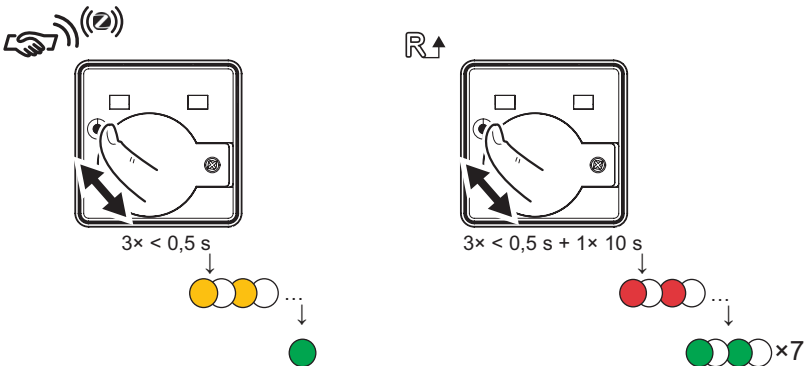
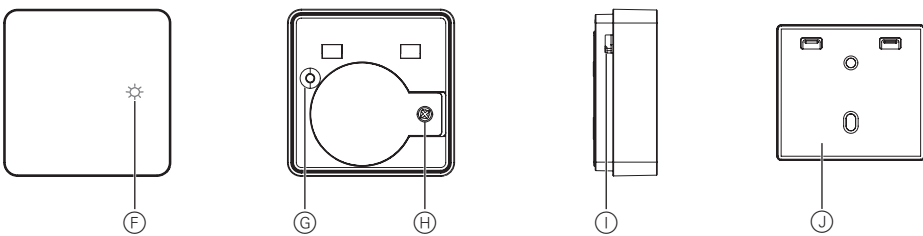
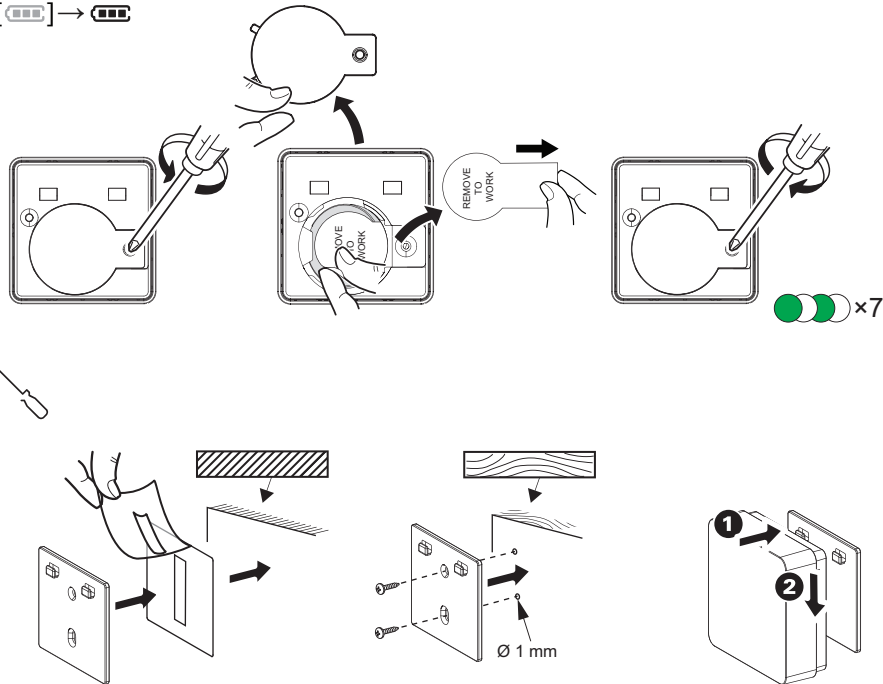
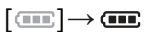
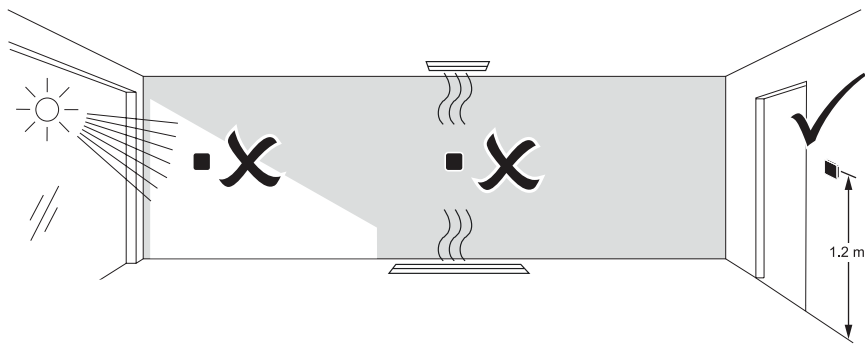
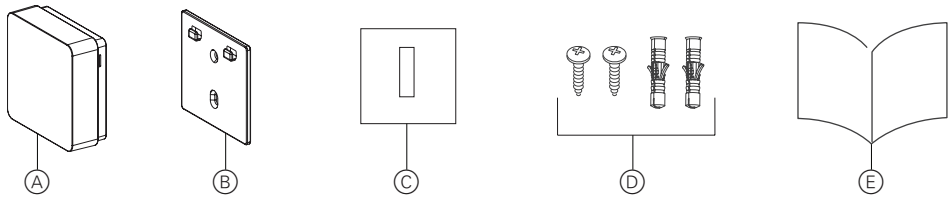
**Prerequisites**

Download the **Wiser app** to your smartphone / tablet, and install the **Wiser Gateway** to configure and control Wiser devices.

Additional system information

Detailed product information is available online in the **system user guide**: Scan the QR code or follow the link.

<https://www1.lk.dk/wiser>**For your safety****NOTICE****RISK OF DAMAGE TO DEVICE**

Always operate the product in compliance with the specified technical data.

Failure to follow these instructions can result in equipment damage.

Getting to know the product

The Wiser wireless climate sensor (hereinafter referred to as **sensor**) combines two sensors in one unit.

The sensor measures temperature and humidity in the environment where the sensor is installed.

When the sensor is connected to the Wiser Gateway, it directly reports temperature and humidity data to the Gateway.

When the battery is low (less than 10%), the status LED blinks orange once per minute, and a message is sent to the Gateway.

Package contents

- (A) Sensor
- (B) Base plate
- (C) Adhesive pad
- (D) Screws: 2 × ST4.2 × 25 mm with wall plugs
- (E) Installation instructions

Choosing the installation location

Install the sensor as per the suggested location.

i Do not install the sensor in a place where there is strong sunlight or wind (for example, close to the ventilation).

Mounting the sensor**Removing the battery isolation strip****Mounting**

- i** For wood or plastic surfaces, use either the adhesive pads or the mounting screws.
- If using screws, pre-drill a 1 mm hole.
- For metal surfaces, use the adhesive pads only.

Operating elements

- (F) Status LED
- (G) Function key
- (H) Base cover screw
- (I) Temperature and humidity sensor holes

i To ensure accurate temperature and humidity measurement, do not block the sensor holes.

- (J) Base plate

Setting the sensor

i Remove the master part from the base plate to access the function key (G).

Connecting to the Wiser Gateway

- 1 Short press (< 0,5 s) the function key 3 times. The sensor scans for the available Zigbee network. The status LED turns green if the sensor successfully connects to the Gateway.
- 2 Follow the instructions in the Wiser app to set the sensor parameters through the Gateway.

Resetting the sensor

Short press (< 0,5 s) the function key 3 times and then long press the function key once for >10 s to reset the sensor to factory default mode.

i All configuration data, user data, and network data is deleted.

Replacing the battery**Behaviour of the status LED**

Refer to the system user guide.

Troubleshooting

Refer to the system user guide.

Technical data

Battery	3 VDC, CR2450
Battery life	Up to 5 years (may vary based on the usage, frequency of firmware update and environment)
Nominal power	≤90 mW
Operating frequency	2.4 GHz
Max. radio-frequency power transmitted	≤7 dBm
IP rating	IP20
Operating temperature	-10 °C to 50 °C
Temperature accuracy	±1.5 °C
Temperature resolution	0.1 °C
Relative humidity	10 % to 95 %
Humidity accuracy	±5 %
Dimensions (H × W × D)	45.0 × 45.0 × 17.2 mm
EU declaration	1003619-0
Certification	Zigbee 3.0

Dispose of the device separately from household waste at an official collection point. Professional recycling protects people and the environment against potential negative effects.

Trademarks

- Zigbee® is a registered trademark of the Zigbee Alliance.
 - Apple® and App Store® are brand names or registered trademarks of Apple Inc.
 - Google Play™ Store and Android™ are brand names or registered trademarks of Google Inc.
- Other brands and registered trademarks are properties of their relevant owners.

EU Declaration of conformity

Hereby, Schneider Electric Danmark A/S, declares that this product is in compliance with the essential requirements and other relevant provisions of RADIO EQUIPMENT DIRECTIVE 2014/53/EU. Declaration of conformity can be downloaded on: se.com/docs.

Lauritz Knudsen

Schneider Electric Danmark A/S, Lautrupvang 1, 2750 Ballerup, Phone.: +45 88 30 20 00, www.lk.dk